

Wirsbo CoSy Radio

Installation and Operating Instructions



Contents

1. Overview	3
2. Room thermostat	3
2.1 Thermostat models	3
2.2 Function	4
2.3 Positioning.....	4
2.4 Setting and limiting room temperature (basic thermostat)	4
2.5 Setting room temperature (public thermostat)	4
2.6 Temperature Set-back	4
2.7 Battery and changing the battery	5
3. Base unit with accessories	5
3.1 Models	5
3.2 Function	5
3.3 Current limiter	5
3.4 Positioning of base unit.....	5
3.5 Internal and external antenna.....	5
3.6 Alarm	6
3.7 Pump control.....	6
3.8 Valve exercise	6
3.9 Timer module	6
4. Installation and Wiring	7
4.1 Preparing for installation.....	7
4.2 Installation & Wiring of the base unit.....	7
4.3 Installation of external antenna	8
4.4 Pump control.....	8
4.5 Installation of timer module.....	8
4.6 Registering thermostats	8
4.7 Completing the installation - transmission test	8
5. Registration and test functions	9
5.1 Control panel.....	9
5.2 Thermostat transmission button.....	9
5.3 Registering thermostats	9
5.4 Deregister one thermostat	10
5.5 Deregistering all thermostats	10
5.6 Transmission test.....	10
5.7 Thermostat in transmission mode.....	10
5.8 Output (Actuator) test.....	11
6 Technical data	12
7 Notes	13
8 Wiring diagram	14

1. Overview

Wirsbo CoSy Radio is a wireless room temperature control system for underfloor heating systems in particular. The main components of the system are the room thermostats and the base unit. Radio signals are transmitted from the thermostats to the base unit, and because the thermostats are wireless, installation is fast and simple both in new buildings and existing buildings.

Wirsbo CoSy Radio is CE-marked and has been approved for use throughout the EU and in all former EFTA countries.

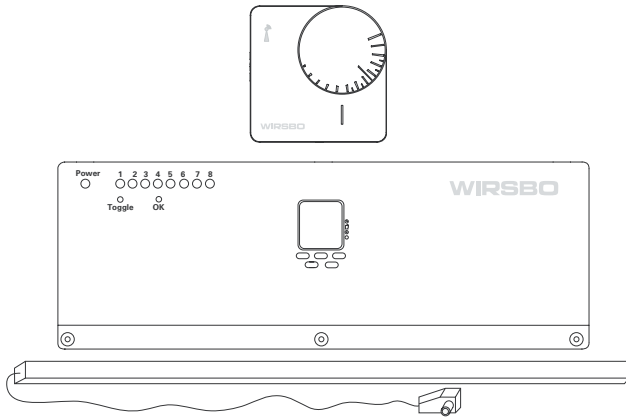

Fig. 1 A complete Wirsbo CoSy Radio system - thermostat, base unit with timer, and the extern antenna.

Function

The room thermostat is installed in the room to be controlled. Radio signals carrying room temperature information are transmitted to the base unit at 2-30 minute intervals. If the room temperature is too low, the base unit opens the corresponding actuator. If the room thermostat stops transmitting, e.g. when the battery has become discharged, an alarm is triggered.

The battery-operated room thermostat can easily be relocated so that it can accommodate any future change in the use of the room. One room thermostat is able to transmit signals to several base units, thereby controlling several loops in a large room or loops connected to different manifolds.

Room thermostat

The room thermostat is available in 2 models. For the basic thermostat the temperature is set by turning a dial with raised markings. On delivery the setting range is 6-30°C, but the range can be limited mechanically by moving the pins underneath the dial.

The public thermostat has a completely plain front cover. Controls are concealed controls and all settings are made inside the thermostat.

The thermostats do not start transmitting until they are activated on installation. There is no transmission before this takes place, which means that there is no battery consumption. In normal operation the life of the battery is estimated to be at least 5 years. The battery can be changed without tools.

Base unit

On the base unit there is a control panel consisting of buttons, which are used to install the room thermostats and LEDs to monitor the operation. The base unit is located close to the manifold and connected to 230 V.

The base unit is available in two models: 4-channel or 8-channel for use with 24 V actuators. One thermostat can be registered to control several actuators. A built-in electronic current limiter ensures that the base unit is not overloaded. If several channels demand heat simultaneously, the actuators will be switched on gradually as the current consumption in the actuators falls.

The base unit can also control a circulation pump, i.e. switch-off the pump when there is no heat demand.

Accessories

If there is poor reception of the radio signals, an **external antenna** can be connected to the base unit. For the 8-channel base unit, a **timer module** for programmable set-back temperature control is available.

2. Room thermostat

2.1 Thermostat models

Two models of room thermostat are available - a basic thermostat with a set-back switch, and a public thermostats with a plain front cover. The public thermostat is designed mainly for use in a public environment. Both thermostats have the same functions, but for the public thermostat all settings are made inside the thermostat.

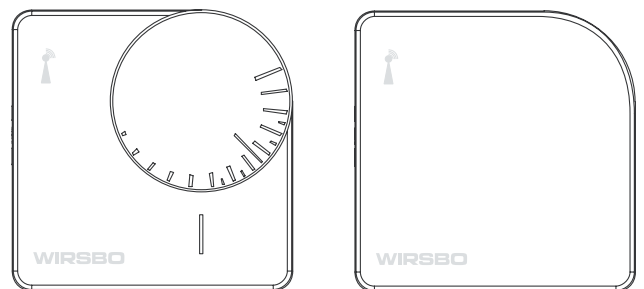

Fig. 2 Wirsbo CoSy Room Thermostat Basic and Wirsbo CoSy Room Thermostat Public

2.2 Function

Radio signals carrying information on the temperature in the room are transmitted at 2-30 minute intervals to the base unit. The signal is repeated twice at short intervals to reduce the risk of possible interference. When the thermostat is transmitting a green LED inside the top of the thermostat is illuminated. If the room thermostat stops transmitting, e.g. when the battery has become discharged, an alarm is triggered (see 3.6 Alarm).

To enable the base unit to distinguish between the signals from the different room thermostats an ID number, unique to the thermostat, is also transmitted with each radio signal. For these signals to be received correctly each thermostat must therefore be registered to the base unit. The thermostat can be registered to control several channels and even registered to control channels in several base units. The number of actuators controlled by the same room thermostat in the same base unit should be limited as the actuators will be switched-on in sequence if several channels demand heat simultaneously. (See 3.3 Current limiter)

2.3 Positioning

The thermostat must be registered to the base unit before it is mounted on the wall. The thermostat should be positioned on an interior wall 1.5 - 2 m above the floor. Wherever possible, it should be installed in a place where the effect of sunlight, draughts, heaters, TV's etc. is avoided. In rooms containing a considerable amount of moisture and steam, e.g. bathrooms, the thermostat should be located as far away from the moisture source as possible.

2.4 Setting and limiting room temperature (Basic thermostat)

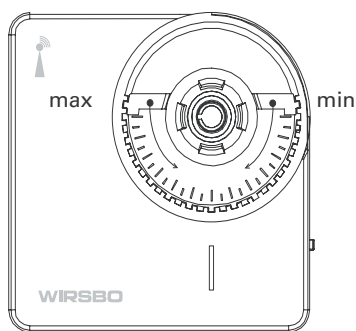

Fig. 3 Setting the min./max. temperature

The temperature is set with a dial, which has raised markings. The position of the long thin line on in the centre of the dial corresponds to approx. 21°C. If the dial is turned clockwise the temperature setting is raised (indicated by longer lines), and if it is turned anticlockwise the temperature setting is reduced (indicated by shorter lines).

On delivery the setting range is 6-30°C, but removing the dial and adjusting the pins underneath can limit the range. If the pins are pressed in towards the thermostat they can be moved to a new position along a graduated scale. The divisions on the scale correspond to 1°C and the graduation indicates the deviation from the reference value, which is approx. 21°C.

The highest temperature that can be set is 30°C. In this case the left pin is in position 9 ($21 + 9 = 30$). To set 26°C as the highest room temperature, the pin is moved to position 5 ($21 + 5 = 26$).

The lowest temperature that can be set is 6°C. In this case the right pin is in position -15 ($21 - 15 = 6$). To limit the lowest setting to 14°C, the pin must be moved to -7 ($21 - 7 = 14$).

2.5 Setting room temperature (Public thermostat)

The temperature is set on the potentiometer inside the thermostat. On the printed circuit board there are markings, which show the temperature setting in different potentiometer positions. The position where the arrow on the potentiometer points straight up corresponds to approx. 18°C.

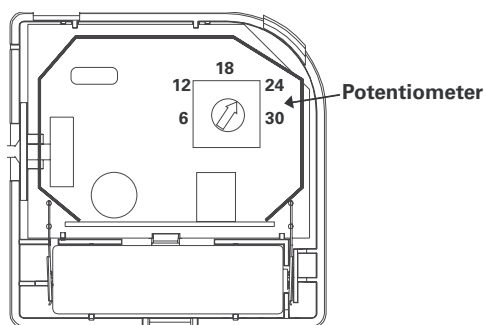

Fig 4 Open public thermostat

2.6 Temperature set-back

Temperature set-back is activated by the switch on the side of the thermostat. For the public thermostat, the front cover has to be removed to access the switch and so where temperature set-back is required, this thermostat should only be used with the timer module.

- If the switch is placed in the “clock” position (upward), the setting is changed between the normal (set) room temperature and the temperature reduction according to programmed settings on the timer module (available only for the 8-channel base unit). If a timer module has not been fitted, the room temperature will be controlled according to the setting on the dial/potentiometer.
- If the switch is placed in the “sun” position (centre position), the room temperature is controlled according to the setting on the dial/potentiometer.
- If the switch is placed in the “moon” position downward), the room temperature is controlled to approx. 4°C below the setting on the dial/potentiometer.

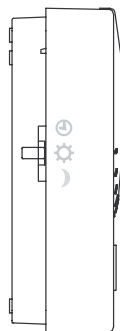

Fig. 5 Temperature set-back switch

2.7 Battery and changing the battery

The thermostat is supplied with the battery fitted. To minimise energy consumption and avoid unnecessary radio signals during the storage period, the battery connection is not activated until the thermostat is registered to the base unit.

The battery is a 3.6 V lithium battery, 2000 mAh, size AA and is estimated to have at least a 5-year life. If the battery becomes discharged, preventing the base unit from receiving signals from the thermostat, the base unit triggers an alarm. (See 3.6 Alarm).

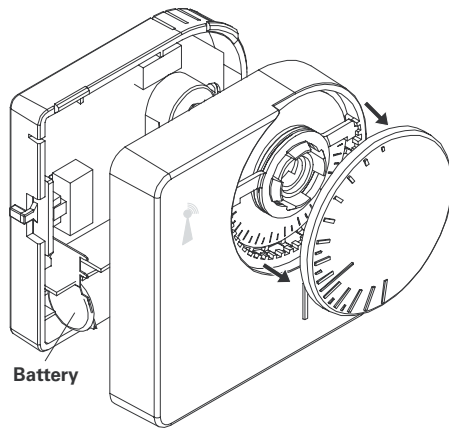

Fig. 6 Changing battery

When the battery is changed care should be taken not to damage the delicate electronics inside the thermostat!

- Remove the thermostat from the wall
- Remove the dial.
- Loosen the front of the thermostat by gently prizing off the bottom of the thermostat.
- Change the battery.
- Press the transmission button on the back of the thermostat and check that the LED in the upper corner lights up as the thermostat is transmitting
- Replace the front and dial.
- Put the thermostat in transmission mode by pressing the transmission button for at least 3 seconds (see 5.7 Thermostat in transmission mode).
- Remount the thermostat on the wall and check at the base unit if the signals are received.

All used batteries must be disposed of for recycling.

3 Base unit with accessories

3.1 Models

The base unit is available in two models: 4-channel or 8-channel. The 4-channel unit has a separate output for pump control. For the 8-channel base unit, one of the outputs can be used for pump control instead.

3.2 Function

There is a control panel on the base unit (see 5.1 Control panel), which is used to register the room thermostats and monitor their operation. The base unit is located close to the underfloor heating manifold and connected to 230 V.

The 4-channel base unit has 4 input channels for thermostats, which can control 4 outputs channels for 24 V actuators. The 8-channel base unit has 8 input channels for thermostats, which can control 8 outputs channels for 24 V actuators.

To enable the base unit to distinguish between the signals from the different room thermostats an ID number, unique to each thermostat, is also transmitted with each radio signal. In order for the signals to be received correctly each thermostat must therefore be registered to a channel in the base unit. The thermostat can be registered to several channels in more than one base unit. If one thermostat is to control several actuators in one base unit, the actuators will be switched on in sequence.

3.3 Current limiter

To prevent the base unit from being overloaded a current limiter is built-in. The current limiter monitors the current to the actuators. When several actuators are switched on simultaneously, e.g. after a prolonged power failure or where

one thermostat controls several actuators, the initial current may become too high. The current limiter determines how many actuators can be switched on immediately, and as the starting current drops further actuators are switched on. A maximum of 2 actuators may be connected to each output and totally a maximum of 12 to the 8-channel base unit and a maximum of 8 to the 4-channel base unit. To avoid uneven floor temperatures the number of actuators controlled by the same room thermostat should be limited to 8 in the 8-channel base unit and to 4 in the 4-channel base unit.

3.4 Positioning of base unit

The base unit should be positioned immediately above the underfloor heating manifold, either on the wall or inside the manifold cabinet. The base unit must be mounted horizontally and in a way that facilitates access to the control panel and removal of the base unit cover. The base unit must not be exposed to water splashing.

3.5 Internal and external antenna

In most cases the radio signals from the room thermostats can be received by the built-in antenna. If reception problems arise, the base unit can be provided with an external antenna to increase the range. If the base unit is installed in a metal cabinet the external antenna must always be used and must be fitted outside of the cabinet. The antenna should be installed at least 70 cm from the cabinet and other metal objects, to avoid interference. **For best reception, the external antenna must always be mounted vertically.**

3.6 Alarm

Signals from the room thermostats are transmitted at intervals of 2-30 minutes. If the base unit has not received a signal from any of the registered thermostats in 2-3 hours, the alarm function is activated. The LED for the relevant channel will start to flash. Whilst a channel is in the alarm condition the actuator output will be continuously activated for seven minutes and closed for 14 minutes.

Where the alarm switch is in the ON position in the base unit (see Fig 10 and 4.2 Installation and wiring of the base unit), an acoustic signal (buzzer) will also start to sound after a further 8 hours if the base unit has still not received a signal. The acoustic alarm is switched off by pressing any button on the base unit.

Once the base unit receives a signal again, the visual and audible alarms will stop. Alternatively interrupting the current to the base unit will shut off all the alarm functions.

Check the following when an alarm is triggered:

1. Remove the thermostat from the wall
2. Remove the dial and loosen the front of the thermostat by gently prying off the bottom of the thermostat.
3. Press the transmission button on the back of the thermostat and check that the LED in the upper corner lights up as a sign of the thermostat transmitting.
4. If the LED:

does not flash: Change the battery See 2.7 Battery and changing the battery

does flash: Put the thermostat in transmission mode by pressing the transmission button for at least 3 seconds (see 5.7 Thermostat in transmission mode). Check with different positions of the thermostat what is interfering with the transmission.

3.7 Pump control

8-channel base unit

Channel 7 and 8 of this base unit are designed to either be used for actuators or alternatively for pump control, etc. For both outputs the pump is started as soon as a thermostat calls for heat. If the pump is connected to channel 7 it will stop as soon there is no call for heat. If the pump is connected to channel 8, it will stop after a 10 minute delay, which means that the circulation pump continues running as the actuators close. If the pump is connected to channel 8 and "valve exercise" has been selected in the base unit, the pump will be exercised daily (see 3.8).

Changing either channel 7 or channel 8 to pump control is carried out according to 4.4 Pump control.

Note! As long as no thermostat has been registered on channels 7 and 8, the outputs will act as pump outputs. As soon as one of the other channels is activated, these channels will also be activated, i.e. if actuator 1 calls for heat, both channel 7 and channel 8 will be activated. If the underfloor heating system is commissioned in stages and the thermostats are registered when each heating loop is commissioned, actuators must not be connected to channels 7 and 8 until their thermostats have been registered and the heating loops coils have also been commissioned.

4-channel Base unit

The pump is connected to the separate pump output. The pump is started as soon as a thermostat calls for heat and stops after a 10 minute delay after the last call for heat. If valve exercise is selected (see below), the pump will be exercised daily.

The separate pump output has no LED on the control panel.

3.8 Valve exercise

Valve exercise is used to prevent the underfloor heating manifold valves from seizing or sticking after a prolonged inactive period. All the actuators and occasionally the pump are activated for 5 minutes once a day. The LEDs will go on and off according to the valve exercise. During this exercise period LEDs will not flash if any of the thermostats transmit, but the signals are registered and when the exercise cycle is completed the actuators will be controlled according to the signal.

The exercise is performed at the same time of day as the time when the base unit last time was connected to 230 V. Interrupt and then re-connect the power at desired time to change the time of the exercise.

Valve exercise cycle:

- All terminals with a registered thermostat are activated for 5 minutes
- All outlets are closed 5 minutes
- Pump terminal on base unit with 4 outlet and terminal 8 (8-channel if no thermostat is registered) are activated for 5 minutes
- Pump terminal and terminal 8 are closed for 5 minutes

The function is deactivated by setting the valve exercise function switch in the base unit in position OFF (see Fig 10 and 4.2 Installation and wiring of the base unit).

3.9 Timer module

A timer module, which is used for programmed temperature set-back, is available for the 8-channel base unit. The timer is a 2-channel 7-day digital clock, which is supplied recessed in a new cover to fit the base unit. Timer channel 1 controls the temperature set-back for base unit channel 1, 3, 5 and 7, and channel 2 controls the temperature set-back for base unit channel 2, 4, 6 and 8.

For installation see 4.5 Installation of timer module. Settings are made according to the separate manual supplied with the timer module.



Fig. 7 Removing and replacing base unit cover.

4. Installation and wiring

Installation and wiring must be carried out by a suitably qualified person.

4.1 Preparing for installation

Prepare for the installation by deciding which underfloor heating loops are to be connected to which channels and which thermostats. If using the timer module for programmed temperature set-back, consider using the timer's capacity for programming two different time programs (channel 1 and channel 2) and the actuators which will be registered to either channel (timer channel 1 = base unit channel 1, 3, 5, 7 and timer channel 2 = base unit channel 2, 4, 6, 8).

Before installation commences, mark each thermostat with a room designation or similar to avoid confusion. Enter all the information in chapter 7 Notes.

4.2 Installation and wiring of the base unit

Position the base unit immediately above the underfloor heating manifold, either on the wall or in the manifold cabinet. The base unit must be mounted horizontally and in a suitable position for ease of access to the control panel and for removal of the base unit cover. Secure the base unit with two screws. Installation is easier if the cover is removed first. There is a plug connection to the 230 V mains.

1. Ensure that the base unit is isolated from the mains.
2. Slacken the screws and lift the cover.
3. Remove the internal antenna (the green frame)
4. Remove the LED cable at the bottom of the base unit, then remove the base unit cover.
5. Install the base unit above the underfloor heating manifold.
6. Connect the cables from the actuators to the relevant terminal block. Connect a maximum of two actuators per terminal block. The blue terminal blocks can be detached from the board for easy connection.
7. Check that the actuators have been connected to the correct output.
8. Pump control in 4-channel base unit: connect the pump to the separate pump terminal block.
Pump control in 8-channel base unit: connect the pump to either output 7 or 8, which should then be re-wired. See 4.4 Pump control.
9. Install the timer module where used. See 4.5 Installation of timer module
10. Check that the selector switch for actuator type (SW1 Actuator) at the bottom of the base unit is in the NC position.
11. Check that the selector switch for valve exercise (SW2 Exercise) is in the desired position. (See 3.8 Valve exercise).
12. Check that the selector switch for acoustic alarm (SW3 Buzzer) is in the desired position. (See 3.6 Alarm).
13. Connect the LED cable to the LED contact marked MM1 MODULE.
14. Replace the internal antenna or connect an external antenna.
15. Replace the cover.
16. Reconnect the unit to the mains supply / connect the plug.

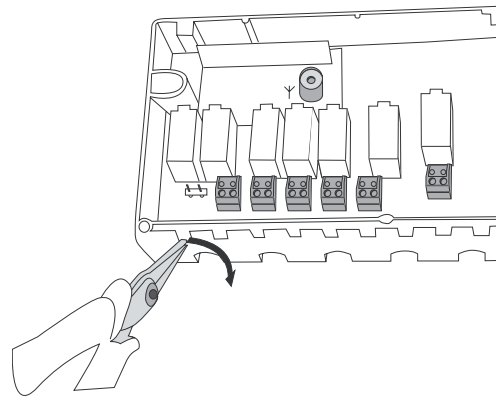

Fig. 8 Break off the plastic where the cable will pass

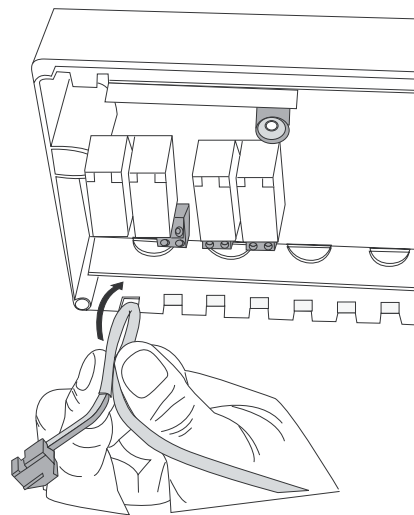

Fig. 9 Squeeze the cable together and push it into the cable channel

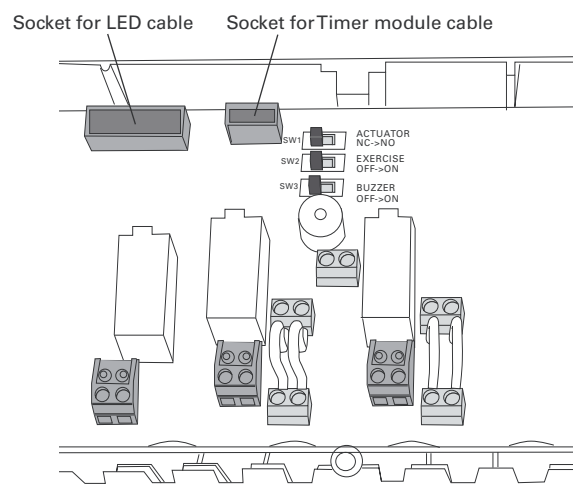

Fig. 10 Switches in base unit

4.3 Installation of external antenna

Connect the antenna to the socket marked Ψ . See 1-3 and 14-16 in 4.2 Installation and wiring of the base unit. The antenna must be mounted vertically for best reception and should be located at least 70 cm from the manifold cabinet and other metal objects. Avoid permanently fixing the antenna in position until the system has been test run to check that all thermostats have good radio contact with the base unit.

4.4 Pump control

In the 4-channel base unit connect the pump to the separate pump output, marked Ψ . In the 8-channel base unit the pump control is connected to output 7 or 8. The operation and difference between the two outputs are described in 3.7 Pump control.

1. Isolate the base unit from the mains.
2. At the relevant terminal block, remove the wire loops which are connected perpendicularly, see Fig. 11.
3. Refit one of the loops as shown in Fig. 12.
4. Connect the pump phase cable to the relevant output.
5. Continue with the installation according to 4.2

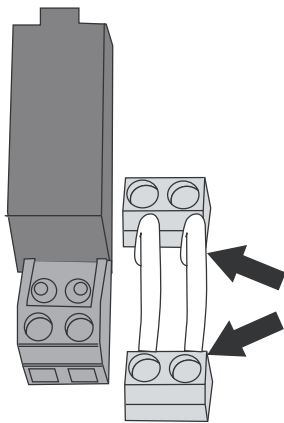

Fig. 11 Changing output / or 8 to pump control. First remove wire loops

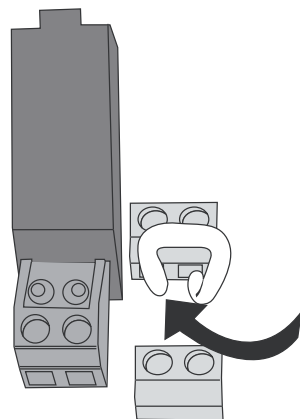

Fig. 12 Changing output 7 or 8 to pump control. Refit one of the loops.

4.5 Installation of timer module

(For 8-channel base unit only).

The timer module is supplied fitted in to a new cover for the base unit.

1. Ensure that the base unit is isolated from the mains.
2. Unscrew the base unit cover, loosen the internal antenna and remove the LED cable from the bottom of the base unit.
3. Unscrew the LED panel from the cover and transfer it to the new cover.
4. Reconnect the LED cable to the output marked MM1 MODULE.
5. Connect the timer cable in the output marked TIMER and fit the antenna.
6. Fit and screw on the new cover.
7. Connect the mains.

The timer module is now ready for programming. See separate programming instructions supplied with the timer module.

4.6 Registering thermostats

The system is now ready for registering the thermostats as described in Chapter 5. The thermostats should not be mounted on the wall until they have been registered to the base unit.

Note! 8-Channel Base Unit: As long as no thermostat has been registered on channels 7 and 8, the outputs will act as pump outputs. As soon as one of the other channels is activated, these channels will also be activated, i.e. if actuator 1 calls for heat, both channel 7 and channel 8 will be activated. If the underfloor heating system is commissioned in stages and the thermostats are registered when each heating loop is commissioned, actuators must not be connected to channels 7 and 8 until their thermostats have been registered and the heating loops coils have also been commissioned.

4.7 Completing the installation - transmission test

After all the thermostats have been fitted in position a final inspection of the transmission between thermostats and base unit must be carried out according to 5.6 Transmission test.

If the transmission operates satisfactorily any external antenna supplied can be permanently installed. Also check that the table in chapter 7 Notes has been correctly completed.

5. Registration and test functions

5.1 Control panel

The base unit control panel consists of a series of LEDs and buttons indicating the following:

- mains voltage
- 4 or 8 LEDs for each output,
- 2 input buttons: -Toggle and OK.

The output LEDs, may either be off, illuminated with a permanent light, or may flash with both a slow and very fast frequency. From now on the term “flash” will be used to refer to slow flashing, and “flicker” for fast flashing.

When the base unit receives a signal from a room thermostat the corresponding LED flashes two-three times.

When the actuator is activated, i.e. call for heat or valve exercise, the corresponding LED illuminates.

If the current limiter causes the actuators to be activated in sequence, all the LEDs concerned come on simultaneously including the LEDs for those outputs not yet activated.

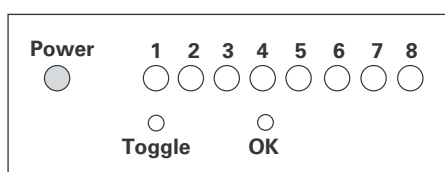

Fig. 13 Control panel

5.2 Thermostat transmission button

On the back of the thermostat there is a transmission button, which can be pressed with the tip of a ballpoint pen or similar. If the button is pressed and immediately released again the thermostat will transmit a signal to the base unit. A new thermostat will, at the same time be activated and will start measuring temperature and send information to the base unit.

If the transmission button is pressed and held for at least 3 seconds, the thermostat will send a signal for 5-6 minutes at 3-7 second intervals. See 5.7 Thermostat in transmission mode.

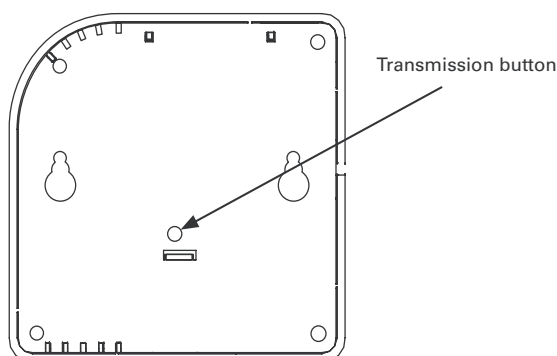

Fig. 14 Transmission button

5.3 Registering thermostats

Put the base unit into registration mode:

- Ensure that the mains voltage LED is illuminated.
- Press and hold the Toggle and OK buttons simultaneously for three seconds. The LEDs will flicker.
- First release the Toggle button and then release the OK button.

The base unit is now in registration mode. The LEDs for the channels, which have thermostats registered light up and the others remain off.

Registering the thermostat:

- Press and release the thermostat transmission button.
- When the thermostat transmits its signal, the LED inside the thermostat flashes. When the signal is received by the base unit the LED for the first free channel will start flashing.
- Press Toggle to select the next free channel.
- When the LED for the required channel flashes, press and hold the OK button to confirm the registration. The LED flickers whilst registration is taking place.
- When the LED is illuminated, registration is completed and the OK button can be released.

If one thermostat is to control several channels, repeat the thermostat registration procedure. Install all thermostats in the same way.

When the final thermostat has been registered, press the Toggle button for approx. 3 seconds. If no button is pressed for about 5 minutes the base unit automatically returns to the normal mode.

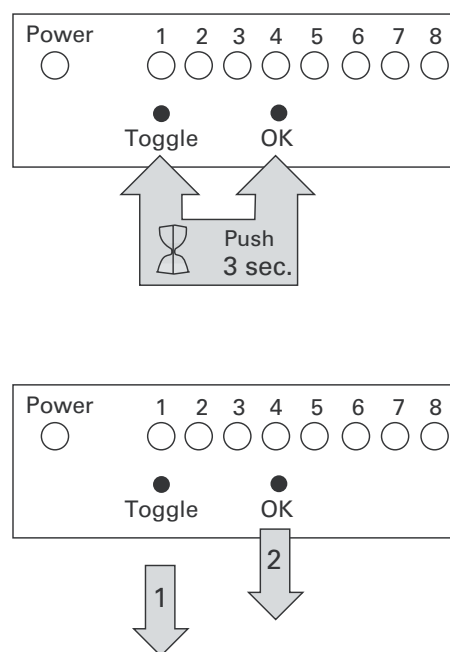

Fig. 15 Setting base unit in registration mode

5.4 De-register one thermostat

See also 5.5 De-registering all thermostats

- Press and hold the Toggle and OK buttons for three seconds. The LEDs flicker.
- First release the OK button then release the Toggle buttons.

The base unit switches to “remove” mode. The LED for the first channel registered to a thermostat flashes and the LEDs for the other channels which have been registered illuminate.

- Press Toggle to select the channel to be un-registered.
- When the LED for the required channel flashes, press and hold the OK button to confirm the de-registration. The LED flickers whilst de-registration is taking place.
- Release the OK button once the LED goes out. De-registration is completed.
- The LED for the next channel with a registered thermostat starts to flash.
- Press Toggle to select a different channel to de-register. Confirm with OK.
- Complete the de-registration process by pressing the Toggle button for about 3 seconds. If no button is pressed for about 5 minutes the base unit returns automatically to normal mode.

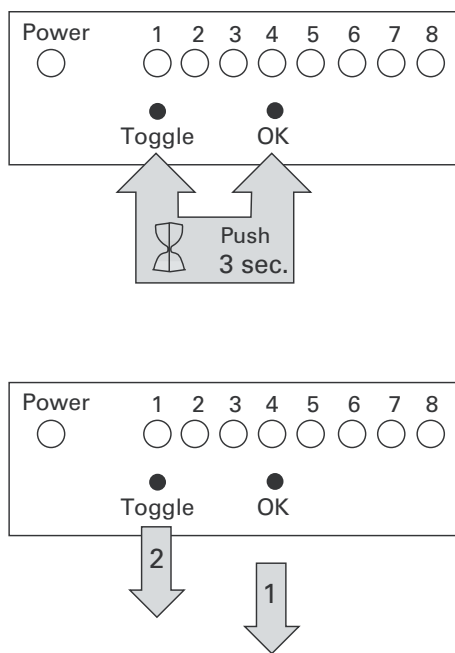

Fig. 15 Setting base unit in “remove” mode

5.5 De-registering all thermostats

- Isolate the power supply to the base unit.
 - Press Toggle and OK simultaneously.
 - Power-up the base unit. The LEDs light up one by one.
 - After all the LEDs have come on they start to flicker. First release OK button and then release the Toggle button. The LEDs flash in turn, then go out.
- All thermostats are de-registered.

5.6 Transmission test

This function is used to check that all channels are receiving signals from the respective room thermostats. Whilst the test is in progress the outputs are temporarily disconnected and all the actuators will close.

- Press the OK button on the control panel until all the LEDs begin to flicker (approx. 3 seconds), then release the button. The LEDs for all channels registered room thermostats are illuminated.

As the base unit receives a signal from a room thermostat the LED for the corresponding channel(s) will flash twice, then go out. LEDs remain illuminated for those channels that have not received a signal from their corresponding room thermostats.

Normally, room thermostats transmit at intervals of up to 30 minutes. To force a transmission, slide the set-back switch. The thermostat will then transmit within two minutes.

- When all the LEDs have gone out, press and hold the toggle button for 3 seconds to complete the test.

The system returns automatically to normal mode approximately 5 minutes after the last channel has received a signal or 15 minutes after the button is pressed for the last time. Those channels that have not yet transmitted will trigger the alarm (see 3.6 Alarm).

5.7 Thermostat in transmission mode

This function can be used to facilitate fault finding if problems arise with the transmission. The thermostat will transmit a signal for 5-6 minutes at intervals of 3-7 seconds, during which time the transmission can be checked for different thermostat and external antenna positions.

- Press the transmission button on the back of the thermostat for at least 3 seconds. During transmission the LED inside the thermostat flashes. When transmission is operating properly the corresponding LED on the base unit will flash after a slight delay.
- Press the transmission button on the thermostat again to complete the transmission test.

It is important to check the transmission whilst the thermostat is close to its final installation position.

5.8 Output (Actuator) test

This function is used to inspect the outputs.

- Press the Toggle button until the LEDs for all the channels start to flicker. When the button is released the LED for channel 1 will alternately flicker and go out (if the terminal is closed before starting the test) or flicker and light up (if the terminal is activated before starting the test).
- Press OK to start the test for channel 1. When the channel is set to test mode the LED starts to flicker, remain illuminated and then go out.

After about 5 seconds a soft “click” will be heard indicating that the output relay has been activated.

- Press Toggle to go to next output. (To go from 8 to 1 Toggle must be pressed twice).
- Press OK to start output test for the current output.
- The led lights up: The output is activated (or is waiting to be activated depending on the current limiter).
- The led is not illuminated: The output has not been activated.
- The led flickers and goes out: The output test has not been activated but can be activated by pressing OK.
- The led flickers and lights up: The output is activated but can be closed by pressing OK.
- The led flickers, lights up and goes out: The output is activated and can be deactivated by pressing OK.

To interrupt the test, press Toggle until all the LEDs flicker.

The system returns automatically to normal mode about 10 minutes after the button has been pressed for the last time.

Note! If several outputs are tested simultaneously, the built-in current limiter will connect the outputs in sequence. Depending on the number of actuators connected, it will take a few minutes for all the outputs to be activated. Hence the output test should not be done with more than 8 and 4 actuators respectively activated at the same time.

6. Technical data

Thermostat	
Colour	RAL 9010
Temperature scale	6-30°C +/- 2 K
Hysteresis	+/-0.5°C
Precision	+/-2°C
Temperature reduction	4°C @ 20°C
Life of battery	At least 5 years
Battery type	3.6 V lithium battery, 2000 mAh, type AA
Signal range	~30m (spherical)
Frequency	433.70 MHz
Transmission interval	2-30 mins.
Ambient temperature	0-50°C
Humidity	Less than 90% RH
Tightness class	IP20

Base unit, general:	
Colour	RAL 9010
Primary mains voltage	230 V AC
Secondary mains voltage	24 V AC
Valve exercise (optional)	Once every 24 hours
Ambient temperature	0-50°C
Humidity	Less than 85% RH
Tightness class	IP20
Fuse 230 V	T200 mA
All settings made are retained in the event of a power failure	
Base unit with 8 outputs:	
Max. number of thermostats	8 (7 if pump control is installed)
Max. number of actuators per unit	12
Max. number of actuators per output	2
Recommended no of actuators per thermostat	Max. 8
Current limitation, 24 V	Approx. 1.5 A
Outputs 1-6	24 V max. 1 A relay controlled
Outputs 7-8	24 V max. 2 A relay controlled, may be connected to relay, 1-pole closing for 230 V max.
Re-activation of Output 8	10 mins.
Base unit with 4 outputs:	
Max. number of thermostats	4
Max. number of actuators per unit	8
Max. number of actuators per output	2
Recommended no of actuators per thermostat	Max. 4
Current limitation, 24 V	Approx. 650 mA
Outputs 1-4	24 V max. 1A relay controlled
Pump output	Max. 2 A, 1-pole, closing for 230 V max
Re-activation of pump output	10 mins.

7. Notes

Output	Timer ⌚	Room	Actuator
1	1		
2	2		
3	1		
4	2		
5	1		
6	2		
7 Ⓢ	1		
8 Ⓢ	2		

Output	Room	Actuator
1		
2		
3		
4		
Ⓢ		

Example:

1	1	Kitchen	1,2
2	2	Bathroom	3

8. Wiring diagrams

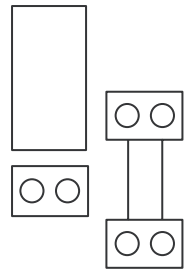
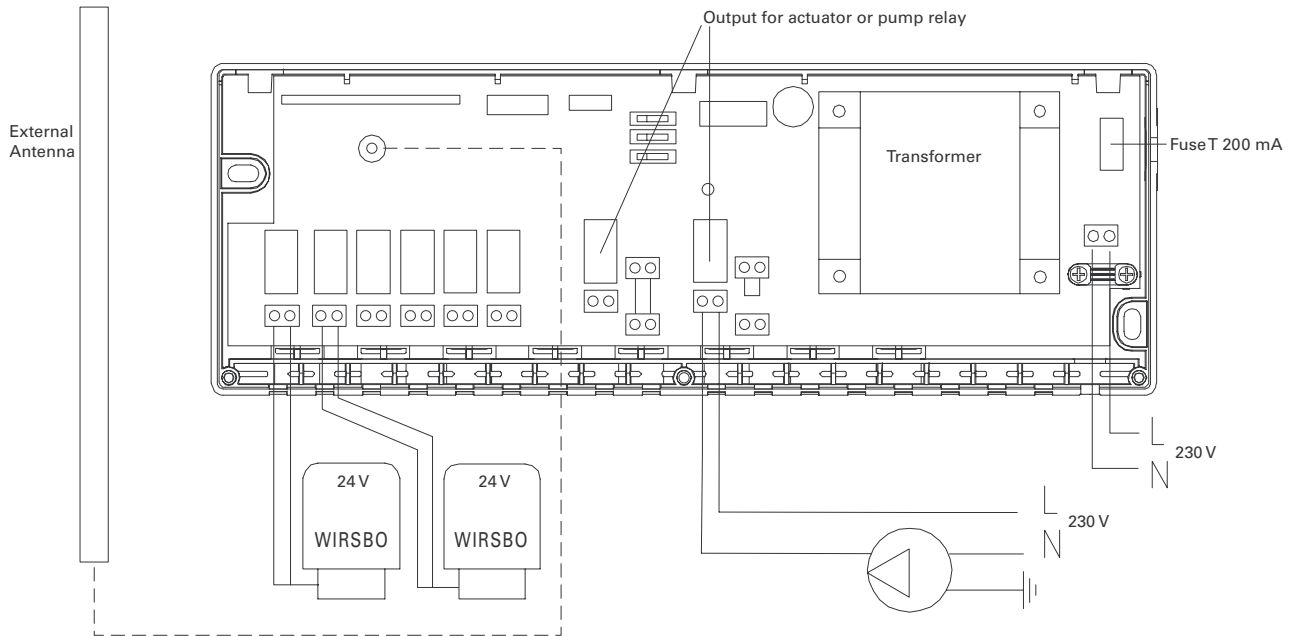

Output 7 and 8 wired for actuator

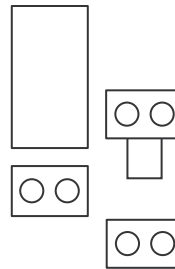

Output 7 or 8 wired as pump relay

Fig. 17 Base Unit, 8 channels

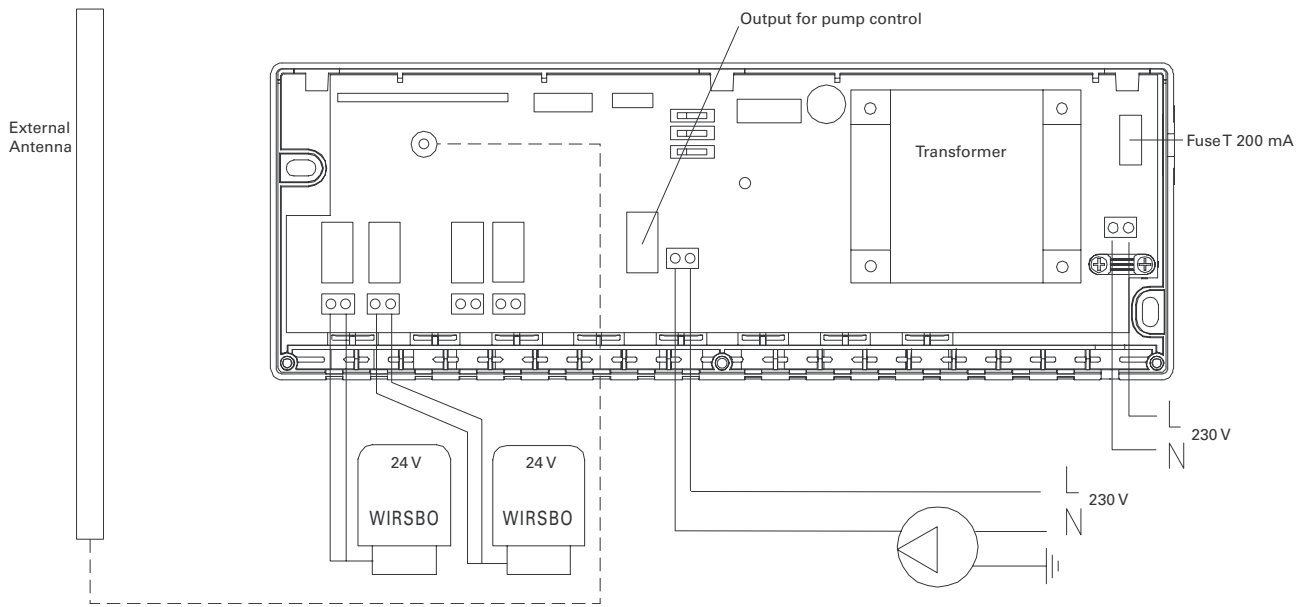

Fig. 18 Base Unit, 4 channels

